



# TOYO

## EFL181

### Electric Forklift 1.8T

- On-board charger provides opportunity charging;
- Compact size;
- Big legroom;
- Trustworthy and mature components.

## FEATURE

### ■ On-board charger provides opportunity charging

Due to the usage of Li-Ion technology in combination with an onboard charger, the EFL181 is the most versatile truck you can find on the market. Plug it into any standard power outlet and the battery will be opportunity charged. No need for any external charging device. Just Plug&Play.



### ■ Compact size

The EFL181 is a very compact truck, while the legroom has been increased for better ergonomics.



### ■ Entry-level forklift

The EFL181 was designed as a universal forklift for the daily operation at few hours per day. The focus lies on the flexible operation, opportunity charging and worry-free technology of the truck at a great price point.



### ■ Trustworthy and mature components

EFL181 uses 10-year market tested components, which offers safety and reliability.



# Electric Forklift 1.8T

## EFL181

Distinguishing mark	1.1	Manufacturer			EP
	1.2	Model designation			TOYO EFL181
	1.3	Drive			Electric
	1.4	Operator type			Seated
	1.5	Load capacity	Q	kg	1800
	1.6	Load center distance	c	mm	500
	1.8	Load distance, centre of drive axle to fork	x	mm	405
	1.9	Wheelbase	y	mm	1260
	Service weight	2.1	Service weight		kg
2.2		Axle loading, laden front/rear		kg	4395/435
2.3		Axle loading, unladen front/rear		kg	1300/1730
Tyres/chassis	3.1	Tyre type			Pneumatic
	3.2	Tyre size, front			6.5-10
	3.3	Tyre size, rear			5.00-8
	3.5	Wheels, number front/rear (x=drive wheels)		mm	2x/2
	3.6	Tread width, front	b10	mm	905
	3.7	Tread width, rear	b11	mm	920
	Dimensions	4.1	Tilt of mast/fork carriage forward/backward	$\alpha/\beta$	°
4.2		Retracted mast height	h1	mm	1995
4.3		Free lift	h2	mm	130
4.4		Lift height	h3	mm	3000
4.5		Height, mast extended	h4	mm	4028
4.7		Height of overhead guard (cabin)	h6	mm	2080
4.8		Seat height/standing height	h7	mm	1060
4.12		Tow coupling height	h10	mm	370
4.19		Overall length	l1	mm	2935
4.20		Length to face of forks	l2	mm	2015
4.21		Overall width	b1/b2	mm	1080
4.22		Fork dimensions	s/e/l	mm	40×100×920
4.23		A,B Fork carriage class/type A, B			2A
4.24		Fork carriage width	b3	mm	1040
4.31		Ground clearance, laden, below mast	m1	mm	115
4.32		Ground clearance, center of wheelbase	m2	mm	120
4.34.1		Aisle width for pallets 1000×1200 crossways	Ast	mm	3525
4.34.2	Aisle width for pallets 800×1200 crossways	Ast	mm	3725	
4.35	Turning radius	Wa	mm	1920	
Performance data	5.1	Travel speed, laden/unladen		km/h	8.5/9
	5.2	Lifting speed, laden/unladen		m/s	0.25/0.3
	5.3	Lowering speed, laden/unladen		m/s	0.43/0.45
	5.5	Drawbar pull, laden/unladen		N	—
	5.6	Max. drawbar pull, laden/unladen		N	10000
	5.8	Max. gradeability, laden/unladen		%	10.5/15
	5.10	Service brake			Hydraulic
5.11	Parking brake			Mechanical	
Electric-engine	6.1	Drive motor rating S2 60 min		kW	6
	6.2	Lift motor rating at S3 15%		kW	7.5
	6.4	Battery voltage/nominal capacity		V/Ah	48/150
	6.5	Battery weight		kg	115
Addition data	8.1	Type of drive control			AC
	10.5	Steering design			Hydraulic
	10.7	Sound pressure level at the driver's ear		dB(A)	70

If there are improvements of technical parameters or configurations, no further notice will be given.  
The diagram shown may contain non-standard configurations.

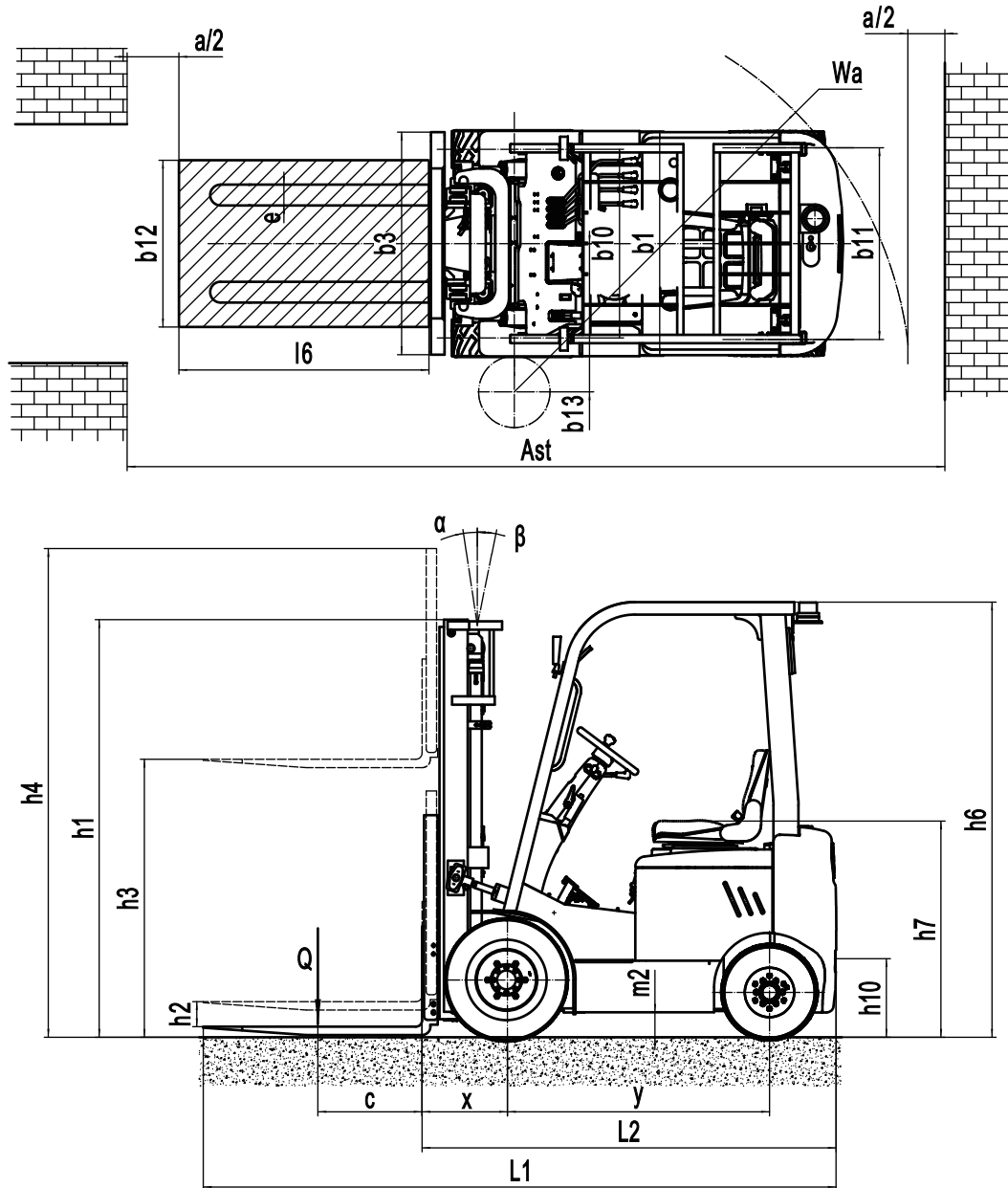

## Mast option:

Mast types	Lift height ( $h3$ )	Height, Mast			Height, Free lift( $h2$ )	
		Height, mast lowered( $h1$ )	Height, mast extended( $h4$ )		No shelving	With shelving
			No shelving	With shelving		
	mm	mm	mm	mm	mm	mm
2-Standard Mast	2500	1745	2985	3528	130	130
	2700	1845	3185	3728	130	130
	3000	1995	3485	4028	130	130
	3300	2145	3785	4328	130	130
2-Free Mast	2500	1778	2985	3528	1293	750
	2700	1878	3185	3728	1393	850
	3000	2028	3485	4028	1543	1000
	3300	2178	3785	4328	1693	1150
3-Free Mast	4350	2000	4844	5378	1506	972
	4500	2050	4994	5528	1556	1022
	4800	2150	5294	5828	1656	1122

## RATED CAPACITIES AND LOAD CENTRES GRAPH

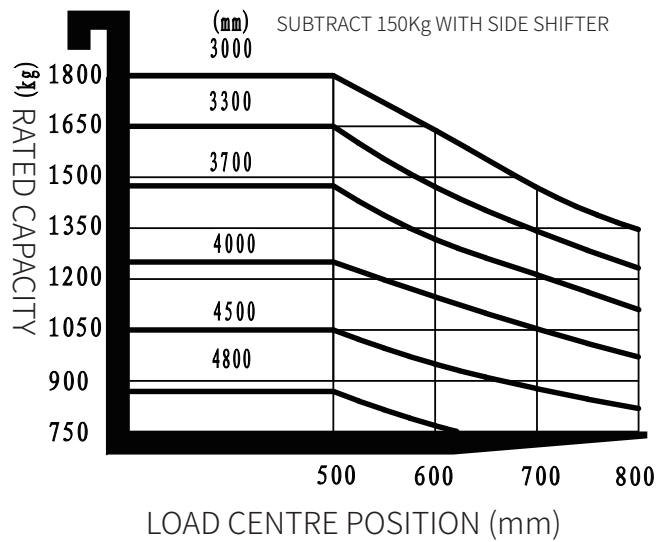

## Option:

No.	Optional items	EFL181
1.1	Fork length	●920○1070
1.4	Fork carriage width	●standard ○Yes and can be customized
1.5	Fork carriage height	●standard ○Yes and can be customized
2.5	Front wheel material	●solid○Non-marking tires
2.6	Rear wheel material	●solid○Non-marking tires
2.7	Battery capacity	●48V150Ah○48V205Ah
2.10	Seat type	●TOYOTA○Suspension
2.11	Attachments	●No○Built-in sideshifter○External shifter○Adjustable fork○clamp
3.5	Front lamp	●LED○NO
3.6	Rear lamp	●No○LED
3.7	Warning lamp	●YES○NO
3.8	Steering lamp	●YES○NO
3.11	Rearview mirror	●YES○NO
3.12	Hummer	●YES○NO
4.3	Cabin	●No○Semi-enclosed cab; front wiper, after wiper

Note: ●Standard ○ Optional - Inconformity

 **PT. BADAQ PRIMA LESTARI**

Kawasan Industri Millenium, Jl. Millenium 15 Blok I-2 No. 3A,

Desa Peusar, Kecamatan Panongan,

Kabupaten Tangerang, Banten 15710 INDONESIA

Tel: +62 59986616 / 30 , Fax.: +62 59986847

www.badakprima.co.id